

### Features

- No generator set supplied
- Maintenance-free lighting tower
- Environmentally friendly, zero emissions
- Compact size reduces transport costs
- Designed specifically for oilfield operating conditions
- Quick and easy power connection
- CSA approved

### Base

- Durable 2000 lb. jacks
- Heavy-duty welded construction
- Powder coated outriggers with spring latch
- Forklift pockets and lifting bail
- Powder coated black colour

### Enclosure

- Lockable access door
- Bolted to the base frame
- 14 gauge, bolted-together construction
- Powder coated
- Stainless steel hardware

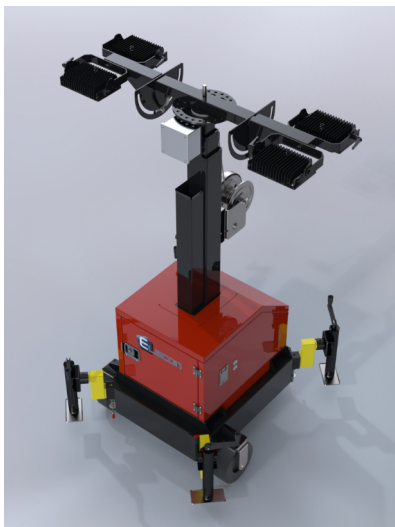

### Light Tower Mast

- Four 160 W LED lamps
  - 360° tower rotation
  - 18 feet extended height
  - Heavy-duty stainless steel cable
  - Vertical light mast with mechanical winch
  - Electrical cord protection
  - 15A, 1Ph plug for power input connection
  - All electrical connectors approved for outdoor application
  - All sections powder coated black
  - Individual breakers for lights
  - Switch for mast control
  - UMHW bushings
- Options:**
- Daisy-chain multiple units
  - Customized colour
  - 250 W LED